





dosmatix products

content

- 04** about dosmatix
- 05** our vision
- 06** our industries
- 08** about our products
- 10** products at a glance
- 12** dispenser
 - 12 dos piston
 - 14 dos screw
- 16** material preparation
 - 16 dos prep light
 - 18 dos prep
 - 20 dos feed C
 - 22 dos feed H
- 24** kinematics
 - 24 dos workstation
 - 26 dos inline
 - 28 dos cell
 - 30 dos vac
- 32** complete systems
- 34** contact

dispensing in perfection.

Accessible for medium-sized companies,
groundbreaking for automated production.

At **dosmatix**, we have made it our mission to design dispensing systems as simply as possible and to develop them according to the modular principle. In this way, we offer our customers maximum added value in procurement and in the operating process.

Medium-sized companies in particular benefit from an uncomplicated entry into automated dispensing technology. Our components are developed with a clear focus on digitalization and the unique advantages of smart production. We attach great importance to optimized maintenance through predictive maintenance and optimized use of resources.

With **dosmatix**, you receive custom-fit, high-quality systems that are tailored to your potting requirements. Our team will provide you with personal and competent support at all times.

Welcome to **dosmatix**.

our vision

„The best dispensing results through excellent performance.“

In our company, excellent performance is the key to everything we do. It forms the basis for our mission to create the highest added value for everyone involved. This is reflected in our daily interactions, in the performance of our systems and in our cooperation with our customers and partners. Our responsible approach to the environment is also an integral part of this philosophy.

Our vision is to achieve the best dispensing results. To achieve this, we always follow our three main pillars: Innovation, digitalization and excellence. These values drive us to continuously push the boundaries of what is possible in order to deliver outstanding results.

from dosmatix
into the world >>

renewable energies

dosmatix potting applications, such as the insulation and potting of electrical components, ensure the durability and robustness of the stressed components of solar modules.

building technology

The focus is on long-term protection against weather influences such as temperature, moisture or frost. The variety of materials is immense. This makes adaptable system solutions for every dispensing task all the more important.

aerospace

dosmatix dispensing systems are extremely economical. The material feed achieves top values in terms of residual quantity utilization - crucial when using expensive high-tech materials.

automotive

dosmatix provides efficient precision processes - for the application of adhesives, the sealing of component joints or the potting and encapsulation of high-quality and sensitive components in vehicles, for example.

industry

Dispensing plays a key role in today's industry. Modular dosmatix system solutions can be easily, quickly and flexibly adapted to the special potting requirements of a wide range of components.

e-mobility

This is where dosmatix masters challenges - such as extremely robust adhesive connections from battery cells or long-term protection against temperature fluctuations, vibration, dirt or moisture.

medical technology

dosmatix solutions offer maximum process reliability for demanding dispensing and potting processes in medical technology, such as a variety of potting and gluing processes in cleanrooms.

consumer electronics

Precise dispensing of materials with different viscosities is crucial for the flawless functionality of a wide range of products, especially in miniaturized layouts in consumer electronics



dosmatix dispensing systems.

The perfect solution for your application.

Every application, every type of material and every customer requirement demands an individual combination of systems to ensure a precise and efficient system. The dosmatix dispensing systems are designed according to the modular principle and thus offer maximum flexibility to optimally cover a wide range of applications.

The right combination of a precise dispensing system, a reliable material supply and the right kinematics solution is crucial for outstanding performance throughout the entire potting process.



dispenser

Different potting requirements such as variable dispensing quantities and cycle times place specific technical demands on the dispensers which are used. dosmatix dispensers offer ideal and tailor-made solutions for the precise potting of a wide range of materials and make an important contribution to the uncompromising top quality of the end products.

material preparation

Potting materials have a wide range of properties. Optimum material preparation (e.g. degassing or tempering) and trouble-free transportation of the material to the dispenser are therefore essential for reliable dispensing. The type of material influences which type of material supply is the right one for the respective application.

kinematics

Different production environments as well as potting and process requirements demand the integration of a dispenser into a manual workstation or a fully automatic kinematic solution. dosmatix offers flexible solutions. They fulfill the latest safety standards and provide tailor-made additional functions to ensure a safe and flawless dispensing process.

dosmatix product portfolio

dispenser



Piston dispenser
dos piston
Material dispensing from 0.1 to 106 ml for abrasive and non-abrasive media.



Progressive cavity dispenser
dos screw
Spot dispensing from 15 µl and continuous bead application at a speed of up to 600 ml/min.

material preparation



Material preparation up to 70.000 mPa·s
dos prep light
Preparation and feeding of abrasive and non-abrasive materials with a filling volume of 0.5 or 3 liters.



Material preparation up to 70.000 mPa·s
dos prep
Preparation and feeding of abrasive and non-abrasive materials up to a viscosity of 70,000 mPa·s.



Material preparation from 70.000 mPa·s
dos feed H
Transport of abrasive and non-abrasive materials in hobbcks from a viscosity of 70,000 mPa·s.



Material preparation from 70.000 mPa·s
dos feed C
Feeding abrasive and non-abrasive materials in cartridges from a viscosity of 70,000 mPa·s.

kinematics



Vakuum chamber
dos vac
Vacuum chamber with integrated axis system for positioning components in 3 degrees of freedom.



Stand-alone
dos cell
Axis system including protection cell for moving the dispenser through 3 degrees of freedom.

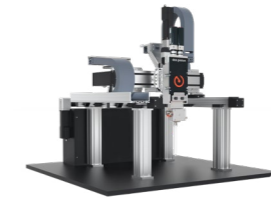

Integration
dos in-line
Axis system for movement of the dispenser in 3 degrees of freedom.



Stand
dos workstation
Stand solution for small series and prototypes.

dos piston

the all-rounder of dispensing.

Material potting from 0.1 ml to 106 ml.

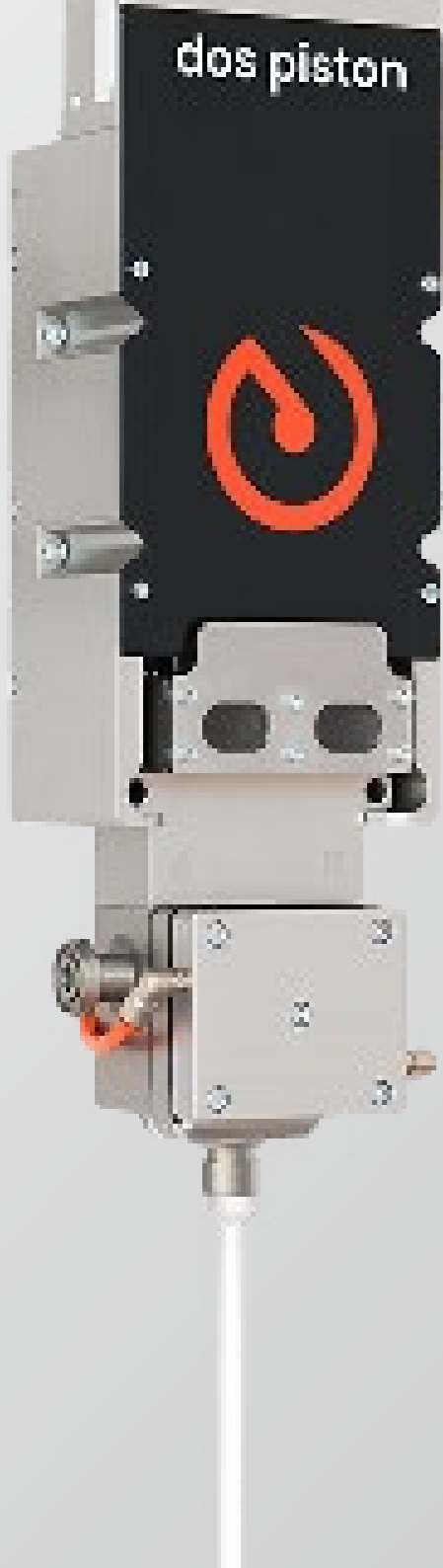

advantages:

- Intelligent system control
- Flexible mixing ratio settings
- Easy system integration
- Innovative construction



Flexible control of the mixing ratio

The **dos piston** has two motors, one for each mixing component. This allows fine adjustment of the material mixing ratio (e.g. resin and hardener) via the software-based individual control of the two motors. The advantages: Maximum flexibility and easy handling.

Sensors and control software

An evaluation of the encoder data enables a reliable prognosis of the status of important parameters. The pot life of each potting material is automatically stored by software to trigger an automatic warning message if the time is exceeded or a flush shot is taken.

Flushing liquid

The cylinder is automatically flushed with every stroke to prevent deposits on the cylinder wall and wear on the valves/seals.

Flow-optimized material transport

All material guides in the **dos piston** have been flow-optimized so that potting material can flow trouble-free and with high performance at every point.

Replaceable dispensing head

The **dos piston** dispensing head can be separated from the lifting unit in just a few simple steps to enable quick maintenance and cleaning work.

Mixing tube with feed screw

A mixing tube with a feed screw is attached at the dispensing outlet to ensure the homogeneous mixing of the components of the potting materials.

Optional functions:

- Equipment for abrasive media
- Dosing head and mixing tube heater

Variant	M	L	M - A (alternating)	L - A (alternating)
Dispensing volume*	0.1 to 43 ml	up to 106 ml	continuous	continuous
Material viscosity	All viscosities			
Dimensions (lxwxh)	110 x 155 x 660 mm	125 x 200 x 775 mm	160 x 275 x 695 mm	185 x 355 x 810 mm
Weight	ca. 12.4 kg	ca. 16.3 kg	ca. 28.2 kg	ca. 39.8 kg

*(Mixing ratio 1:1 2C)

new in > dos screw



Flexible inlet with pressure sensor

The adjustable inlet allows flexible integration in different directions, ideal for adapting to complete systems. The integrated pressure sensor monitors the inlet pressure of the material and thus ensures precise dispensing.

Flow-optimized material guidance

The flow-optimized material guidance in the housing of the stator and rotor ensures maximum performance and optimum dispensing speed.

Precise progressive cavity

The simple control of the dispenser in both directions enables even and continuous material application. This ensures clean dispensing results with controlled tear-off without dripping.

Flexible dispensing outlet

Thanks to the union nut on the outlet, various dispensing needles can be easily connected. This makes the dos screw ideal for a wide range of applications.

Variant	S		M	L	XL	
Quantity per rotation	0.14 ml	0.53 ml	0.35 ml	1.1 ml	2 ml	9.5 ml
max. dispensing speed*	8,5 ml/min	32 ml/min	21 ml/min	66 ml/min	120 ml/min	570 ml/min
min. dispensing quantity*	0.015 ml	0.06 ml	0.04 ml	0.1 ml	0.2 ml	1 ml
Material viscosity	up to 1,000,000 mPa·s					
Dimensions** (lxwxh)	150 x 70 x 140 mm			coming soon		
Weight incl. motor	ca. 3.5 kg			coming soon		

*Depending on the medium

**Incl. mounting clamp and product connection with pressure sensor

dispenser | progressive cavity dispenser

dos screw

endless dispensing power by dosmatix.

Spot dispensing from 15 µl and continuous bead application at a speed of up to 600 ml/min.



advantages:

- Continuous, uninterrupted dispensing
- Clean and high-quality dispensing results
- Excellently qualified for adhesive beads
- Ideal for filler-laden media



Space-saving design

This innovative solution for preparing small volumes saves space by integrating seamlessly into dispensing systems and overall systems - without requiring additional space.

Flexible filling options

The material can be filled in two freely selectable ways: Hose solution or funnel.

Continuous material recirculation

Continuous circulation of the material ensures that consistently high quality results are achieved throughout the entire process.

Fill level monitoring

Two sensors monitor the fill level to prevent interruptions in operation. In addition, sight glasses make it easy for the operator to check the level

Vacuum pump: High performance for bubble-free material

A vacuum pump generates a strong and fast vacuum, which significantly increases the absence of bubbles in the material and ensures optimum material quality.

or

Ejector: Cost-efficient solution for lower requirements

The dosmatix ejector variant offers a budget-friendly entry-level option, ideal for materials with less demanding requirements that still demand reliable performance.

Optional functions:

Heating

The optional equipment with a heater enables heating the material up to 80°C.

Variant	S	L
Volume per variant	0,5 l	3 l
Feed volume	35 ml/stroke	
Vacuum level	5 mbar	
Maximum temperature	80 °C (with option heating)	
Height	570 mm	1070 mm
Weight	6.5 kg	12 kg

new in > dos prep light

material preparation | small volume preparation

dos prep light

smart preparation
for small volumes.

Preparation and feeding with a filling volume of 0.5 or 3 liters.



advantages:

- Efficient preparation of very low volumes
- Space-saving integration
- Two variants for optimum material homogenization
- Ideal for laboratory and research applications

new product by dosmatix

dos prep

material preparation for perfect dispensing

For abrasive and non-abrasive materials up to 70,000 mPa·s.



advantages:

- unmatched feed performance
- process reliability through self-regulation
- industry 4.0-capable sensors
- material preparation in perfection

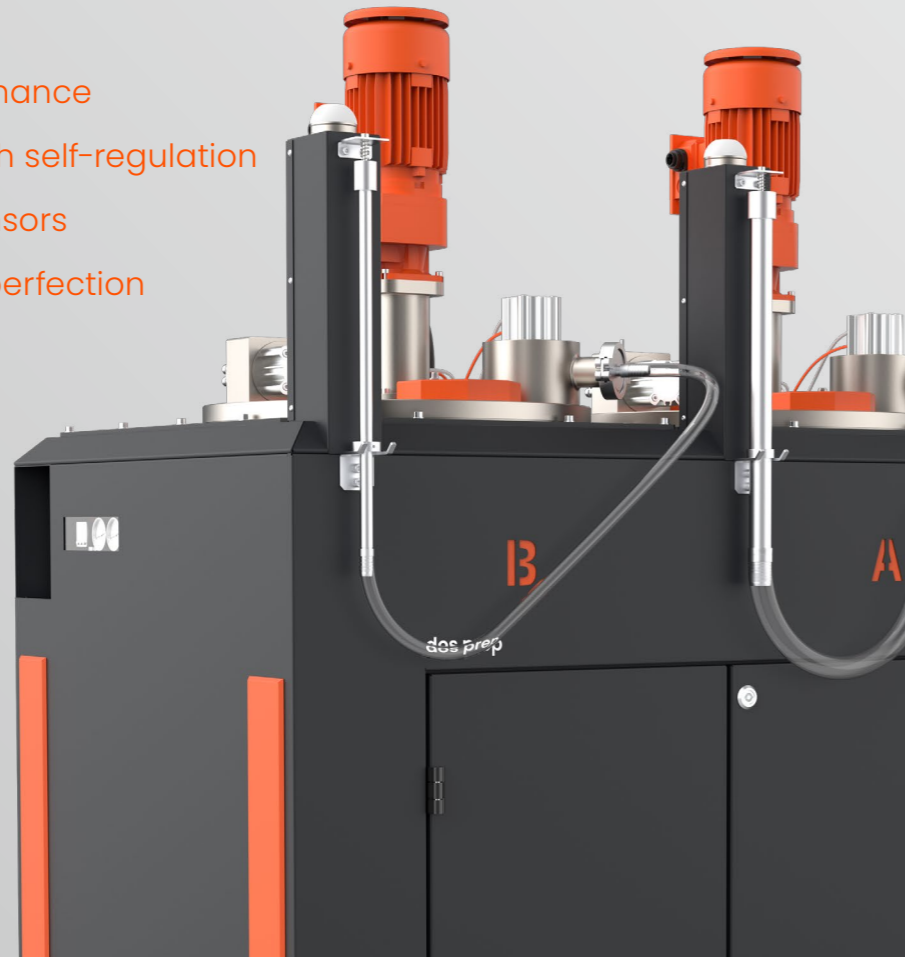

Material preparation | tank wagon

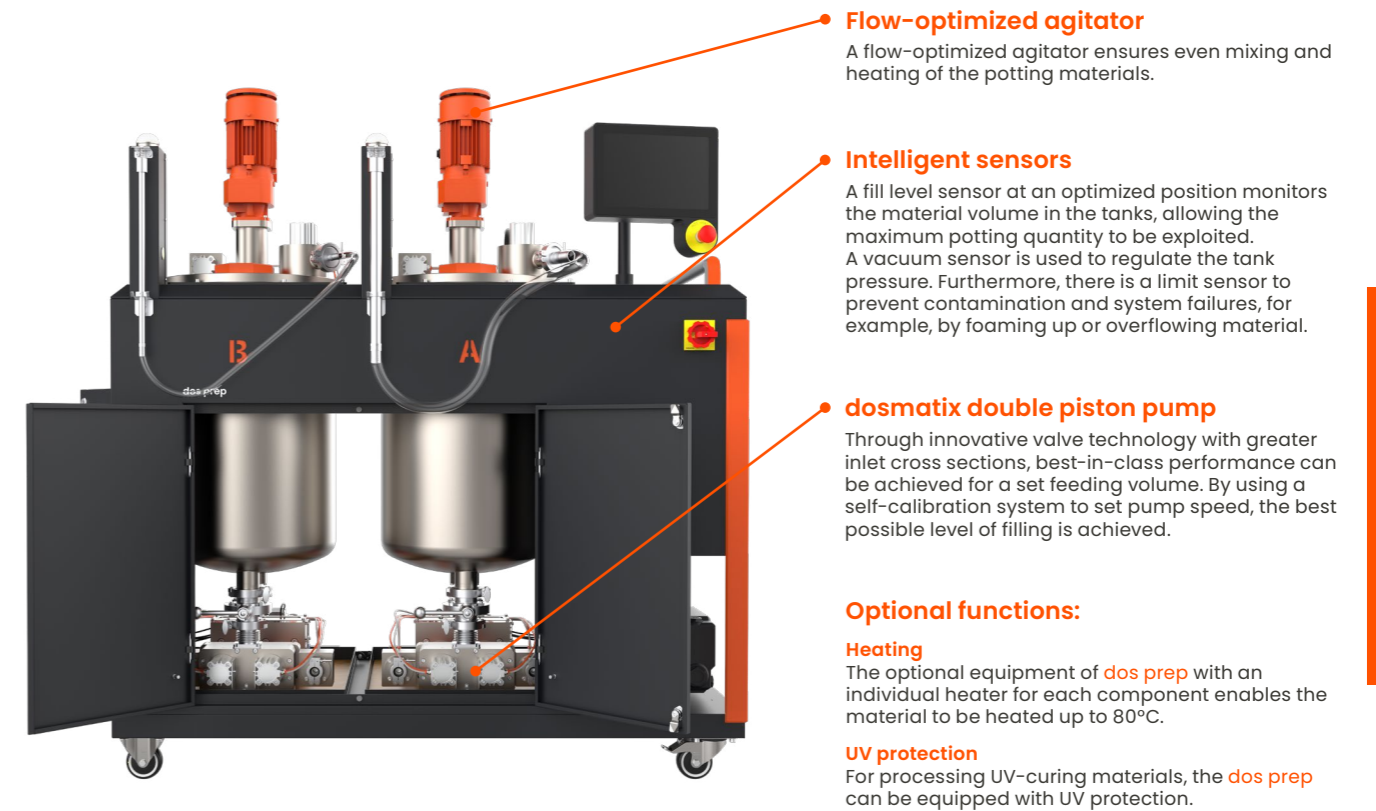

Flow-optimized agitator
A flow-optimized agitator ensures even mixing and heating of the potting materials.

Intelligent sensors
A fill level sensor at an optimized position monitors the material volume in the tanks, allowing the maximum potting quantity to be exploited. A vacuum sensor is used to regulate the tank pressure. Furthermore, there is a limit sensor to prevent contamination and system failures, for example, by foaming up or overflowing material.

dosmatix double piston pump
Through innovative valve technology with greater inlet cross sections, best-in-class performance can be achieved for a set feeding volume. By using a self-calibration system to set pump speed, the best possible level of filling is achieved.

Optional functions:
Heating
The optional equipment of dos prep with an individual heater for each component enables the material to be heated up to 80°C.

UV protection
For processing UV-curing materials, the dos prep can be equipped with UV protection.

material preparation

Variant	1 Component	2 Components
Volume per tank	60 l	
Feed volume	250 ml/stroke	
Feed performance - at least	250 ml/min per component (viscosity of ca. 70,000 mPa·s)	
Feed performance - at least	1500 ml/min per component (viscosity of ca. 1,000 mPa·s)	
Vacuum level	5 mbar	
Maximum temperature	80 °C (with additional option heating)	
Electrical supply	400V AC (3L-N-PE) / 16 A	
Pneumatic supply	Constant 6 Bar, class 5 DIN ISO 8573-1	
Dimensions (lxwxh)	900 x 850 x 1500 mm	1600 x 850 x 1500 mm
Weight	ca. 400 kg	ca. 600 kg
Control system	Beckhoff Automation	

dos feed C

material feeding from cartridges for small series.

For pasty media with a viscosity from 70,000 mPa·s.



advantages:

- Weight-optimized for precise potting results
- Variable sizes for common cartridge types
- User friendly handling

redesigned version



Light construction

A space-saving and lightweight design of dos feed C provides maximum dispensing speed during application.

I/O board

The use of the board enables precise fill level detection over the entire cartridge filling quantity by means of a displacement sensor as well as automatic pressure control for material feed.

Bayonet closure

The use of a bayonet closure provides maximum user-friendliness for the replacement of cartridges.

Bullet valve

A valve is used to perform simple air venting operations.

Variant	S	M
Cartridge size	6 oz. / 180 cc	20 oz. / 600 cc
Weight	ca. 1.20 kg	ca. 2.10 kg
Max. height cartridge holder	432 mm	568 mm
Cartridge diameter	46.50 mm	73 mm

material preparation

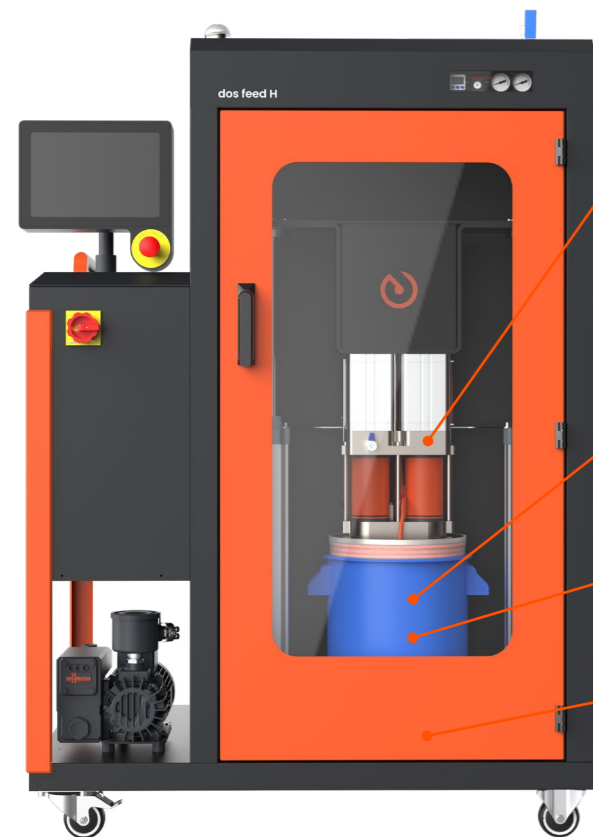

Modular pump concept

dos feed H is optionally equipped with different pumps depending on the requirements:

1. **Vertical piston pumps** for abrasive and non-abrasive materials (up to 35 bar, viscosity up to 500,000 mPa·s).
2. Powerful scoop piston pumps for non-abrasive materials (up to 80 bar, viscosity up to 3 mio mPa·s).

The pumps work on both strokes and thus ensure maximal material transport.

Unique blister technology

dosmatix reduces material waste with an innovative disposable blister. The cost-effective docking plate provides a perfect seal to the hobcock rim and allows the use of different sizes with up to 20 mm tolerance in diameter.

dosmatix degasser dos ventup

For maximum process reliability, the dos ventup eliminates air inclusions in the potting medium.

Robust sensors and intelligent software

Process parameters are independently defined and set. Self-calibration of the pump speed enables fully automatic setting of the feed pump.

Intelligent software eliminates downtimes caused by pressure deviations.

Pump type	Scoop piston pump	Vertical piston pump
Hobcock size (nominal volume)	e.g. 22 litres (standard hobcock)	e.g. 22 litres (standard hobcock)
Feed volume	27 ml/stroke	250 ml/stroke
Vacuum level for degassing process	5 mbar	5 mbar
Electrical supply	230V AC (L-N-PE) / 16A	230V AC (L-N-PE) / 16A
Pneumatic supply	Constant 6 Bar, class 5 DIN ISO 8573-1	Constant 6 Bar, class 5 DIN ISO 8573-1
Dimensions (lxwxh)	1C: 1100 x 790 x 1750 mm	1C: 1100 x 790 x 1750 mm
	2C: 1800 x 790 x 1750 mm	2C: 1800 x 790 x 1750 mm
Weight	1C: ca. 470 kg	1C: ca. 470 kg
	2C: ca. 800 kg	2C: ca. 800 kg
Control system	Beckhoff Automation	

dos feed H



material feeding with maximum material efficiency.

For abrasive and non-abrasive material from 70.000 mPa·s.

advantages:

- Maximum material efficiency up to 99,6 %
- Intelligent plant sensors
- Maximum process reliability
- Pump selection by requirement



dos workstation



stand solution for small series and prototypes.

Compatible with many dispenser sizes.



advantages:

- Economic and space-saving
- Simple to use
- User-friendly
- Compatible and flexible

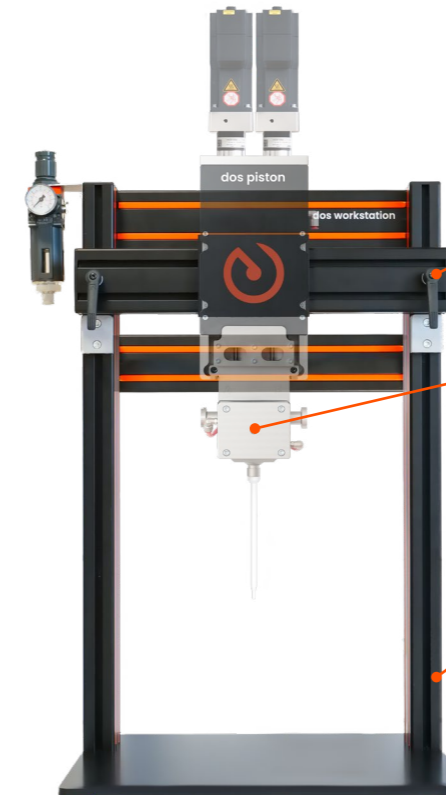

Simple lever mechanism

Thanks to the uncomplicated handling by means of a lever mechanism, the desired position of the dispenser can be set quickly and user-friendly for a precise filling process.

Compatible and flexible

The **dos workstation** is not only compatible with numerous **dosmatix** dispensers, but can also be equipped with various material preparation systems such as the **dos feed C** and **dos prep** and/or the **dos ventup** degassing unit.

Simple potting process

The manual workstation is equipped with a control panel and a foot pedal as standard. The **dos workstation** is ideal for use in laboratories, technical centers or prototype construction where automated cell solutions are not an option.

dos workstation

Dispenser compatibility	different dispenser sizes
Dimension (lxwxh)	736 x 660 x 1037 mm
Weight	ca. 50 kg

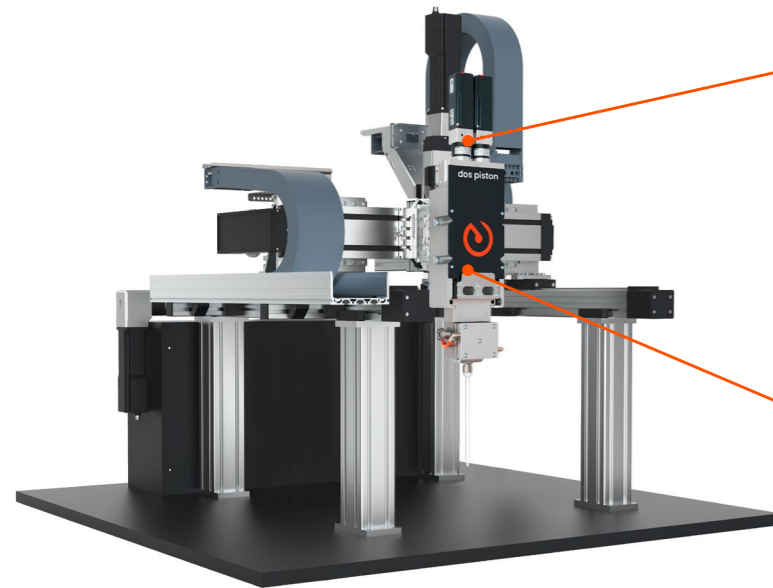

Maximum integration and compatibility

The **dosmatix** material feeding systems can be easily integrated. The universal adapter plate enables flexible and safe installation of the **dosmatix** dispensers.

dosmatix all-in-one solution

The **dos inline** is available in three different sizes for external dimensions and travel range, allowing it to be optimally adapted to different components and the placement of workpiece carriers.

Variant	S	M	L
Dimension (lxwxh)	1250 x 1250 x 1300 mm	1500 x 1500 x 1300 mm	1750 x 1750 x 1300 mm
Weight	ca. 529 kg	ca. 650 kg	ca. 880 kg
Travel area XYZ*	500 x 305 x 300 mm	750 x 555 x 300 mm	1000 x 805 x 300 mm
Max. traverse speed	600 mm/s		
Dispensing speed	35-50 mm/s		
Repeat accuracy	0,05 mm		
Max. Loading	25 kg		
Voltage supply	230 V (Single-phase alternating current)		
Control system	Beckhoff Automation		

* in component with **dos piston M** dispenser and **dos prep** material preparation

dos inline

modular axis system as integration module.

For abrasive and non-abrasive materials up to 70.000 mPa·s.



advantages:

- Maximum integration and compatibility
- Optimal integrability
- Scalable and flexible





dos cell

modular axis system with protection cell for high performance dispensing.

Dispensing movement in 3 degrees of freedom.



advantages:

- Scalable and flexible
- Latest safety standards
- Maximum integration and compatibility
- dosmatix all-in-one system solution



Automated system solution in three different sizes

The system solution is flexible and can be used for various components and workpiece carriers. In addition, the dos cell is available in two versions: with safety door or light curtain. Both versions meet the latest safety standards.

dosmatix all-in-one solution

The system enables easy integration of dosmatix material feeding systems and is equipped with a universal adapter plate that makes it easier to mount dosmatix dispensers. An integrated weighing cell ensures that the material quantities are checked regularly, especially during rinsing processes. The cell solution also offers fully automatic needle measurement.

Optional functions:

- Needle cleaning
- Livestream
- UV curing

Variant	S	M	L
Outside dimensions (lxwxh)	1250x 1250 x 2300 mm	1500 x 1500 x 2300mm	1750 x 1750 x 2300 mm
Weight	ca. 800 kg	ca. 930 kg	ca. 1200 kg
Travel area*	500 x 455 x 300 mm	750 x 705 x 300 mm	1000 x 955 x 300 mm
Max. traverse speed	600 mm/s		
Dispensing speed	35-50 mm/s		
Repeat accuracy	0,05 mm		
Max. Loading	25 kg		
Voltage supply	230 V (Single-phase alternating current)		
Control system	Beckhoff Automation		

* in combination with dos piston M dispenser and dos prep material preparation

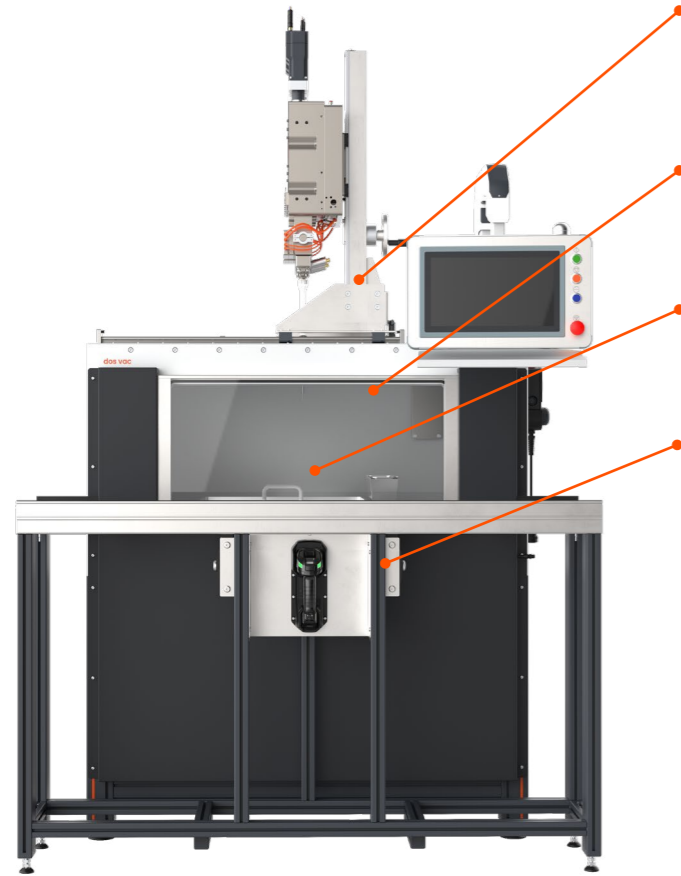

Service slide

An integrated service slide on the **dos vac** enables the user to carry out optimum maintenance and cleaning work on the dos piston thanks to its easy accessibility.

Vacuum door

A generous, transparent door and additional windows provide the operator with an excellent view inside the chamber and improve user-friendliness.

Workpiece holder query

A sensor prevents operating errors and contamination due to incorrect dosing by automatically detecting a missing workpiece holder.

Two-handed operation

The 2-hand control of the vacuum door ensures maximum user safety when closing the vacuum door and therefore contributes significantly to work safety.

Optional functions:

Noise protection cover for vacuum pump
Significantly reduces the noise level and provides greater comfort through noise protection.

> **Automatic air regulation**
Temperature sensor regulates fan speed to prevent overheating in the vacuum pump.

> **Connection to exhaust air system**
Connection to external extraction system possible so that the exhaust air does not enter the production area.

Variant	M	L
Outside dimensions (lxwxh)	1430 x 1450 x 2330 mm	1585 x 1600 x 2480 mm
Outside dimensions chamber	1140 x 790 x 565 mm	1300 x 870 x 685 mm
Weight (excl. vacuum chamber)	ca. 700 kg	ca. 830 kg
Potting area XY*	400 x 300 mm	500 x 350 mm
Travel area XYZ	500 x 320 x 200 mm	600 x 370 x 300 mm
Max. Travel speed	X,Y: 160 mm/s; Z: 50 mm/s	X,Y: 160 mm/s; Z: 50 mm/s
Function	Vacuum potting up to 3 mbar	Vacuum potting up to 3 mbar
Electrical supply	400V AC (3L-N-PE) / 16 A	400V AC (3L-N-PE) / 16 A
Control system	Beckhoff Automation	Beckhoff Automation

* customization possible on request

advantages:

- Maximum functionality and high vacuum sealing
- Maximum production speed
- Comparatively energy-efficient system
- Compact design and modular system structure

dos vac

vacuum dispensing for high-quality potting.



manual workstations

the perfect starter solution

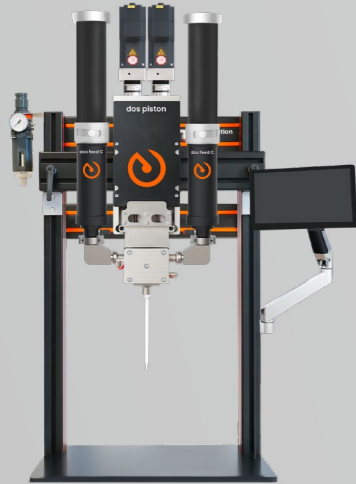

In the illustration example:
dos workstation + dos piston + dos feed C

integration module

integrated and combined individually



In the illustration example:
dos piston + dos inline + dos prep

stand-alone system

automated dispensing systems

potting under atmosphere



In the illustration example:
dos cell + dos piston + dos feed H

potting under vacuum



In the illustration example:
dos vac + dos piston alternating + dos prep

Manual workstations offer an ideal starter solution for manual dispensing. Compared to automated dispensing systems, this product is a cost-effective and space-saving alternative for your dispensing requirements.

Depending on the type of material and dispensing quantity, the stand solution can be flexibly combined with various dispensing systems and material feeds.

Combinable products for kinematics dos workstation

Dispenser: dos piston or dos screw

Material feeding systems: Depending on the material quantity and viscosity - dos prep light, dos prep, dos feed C oder dos feed H

Integration components can be easily integrated into existing dispensing systems or production lines as individual products or in combination. They are ideal for replacing, renewing or expanding existing products.

Products for integration

Dispenser: dos piston or dos screw

Material feeding systems: dos prep light, dos prep, dos feed H or dos feed C

Kinematic: dos inline

Automated dispensing systems as stand-alone systems offer the ideal solution for series products and optimize the potting process through high cycle times and travel speeds.

Depending on the requirements, either an atmospheric or vacuum solution is used. A matching dispensing system and an efficient material feed complete the overall system.

Complete solutions

Dispenser: dos piston or dos screw

Material feeding systems: Depending on material quantity and viscosity - dos prep light, dos prep, dos feed H or dos feed C

Kinematic:

For atmospheric potting: dos cell

For vacuum potting: dos vac

total
systems
at a glance

contact

dosmatix GmbH
Abensberger Str. 9
93352 Rohr i. NB

Phone: +49 8783 9667 50
E-mail: info@dosmatix.com
Web: www.dosmatix.com

sales

Phone: +49 8783 9667 530
E-mail: sales@dosmatix.com

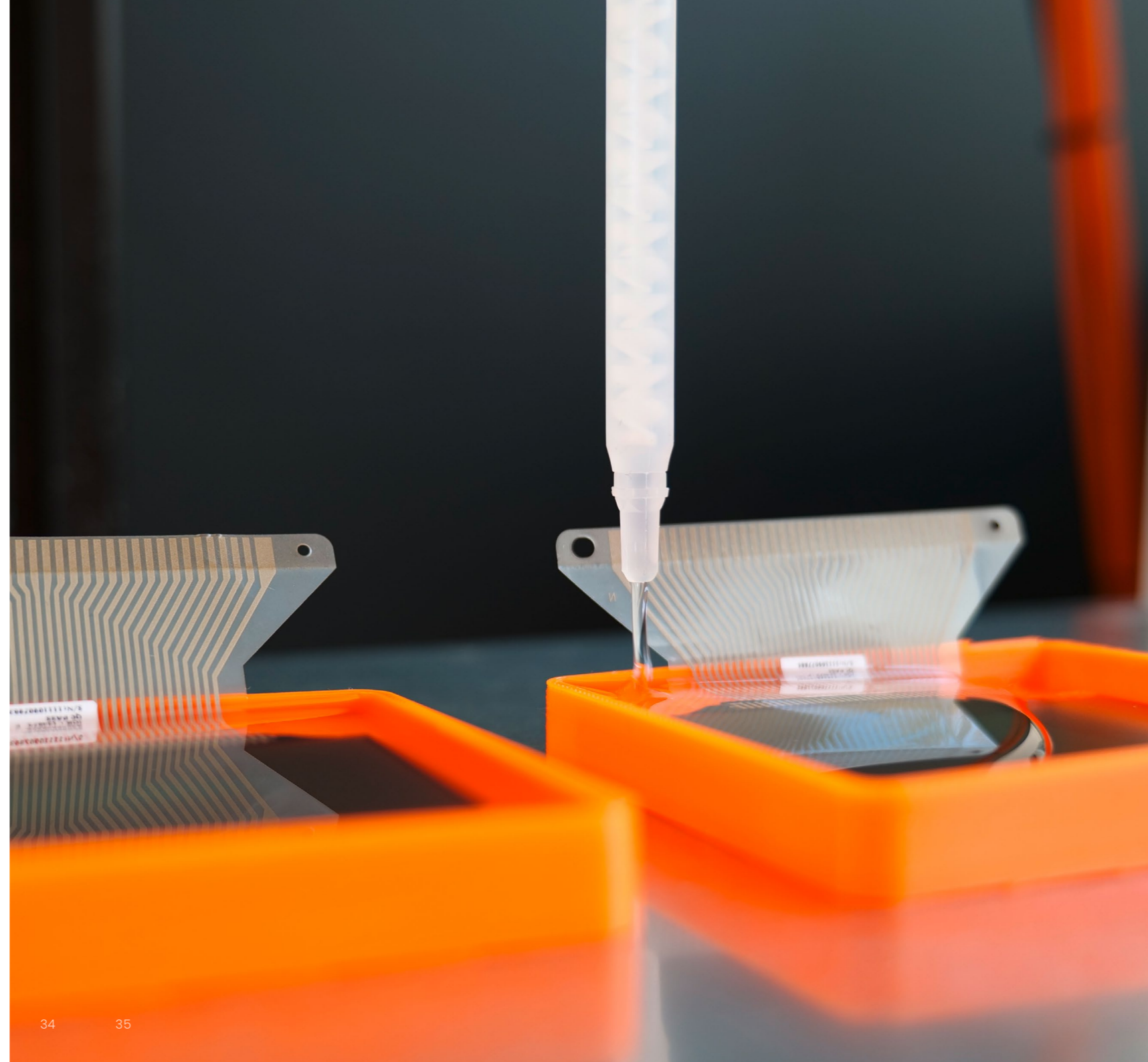



dosmatix.com